

dB Plus II™



Your Best Protection Against Losses

Airmar's dB Plus II™ Acoustic Deterrent System is a proven method of controlling seal predation ever since its introduction in 1993. Our innovative approach of combining a high-powered transmitter with four underwater projectors creates an acoustic barrier that causes significant discomfort to any approaching seal.

The dB Plus II deterrent is the system of choice in North America. This system is the cornerstone of North America's seal exclusion program, with over two hundred currently in use.

Take advantage of the latest seal deterrent technology. Experience the benefits of eliminating seal attacks with no physical damage, reduced stress, and increased fish growth rates.

Optimum Performance

The key to optimal performance is the proper selection and maintenance of batteries and a reliable power source. In remote locations, a wind generator or regulated, four-panel, solar array is the recommended power supply. Locations with shore power can utilize AC mains with a 24 Volt battery charger.

Acoustic Deterrent System

Features

- Up to 3,000 square meters (32,291 square feet) of protection
- Standard system has four underwater sound projectors to create overlapping sound fields
- Self-diagnostic lights on front panel indicate battery status and transmitting mode
- Four independent power amplifiers for measured system reliability
- Transmitter power switch is lockable in the "OFF" position, preventing accidental activation when a diver is in the water
- High-visibility nylon cover for transmitter to warn that a diver is in the water
- Unique "Soft-Start" feature with 70-second ramp up to full-power when transmitter is first switched "ON". This feature provides warning to divers and eliminates chance of hearing loss in seals and sea lions.
- External triggering capability allows system to be activated when predators are detected
- Sound projectors are designed to withstand the harsh marine environment



Sensing Technology

www.airmar.com

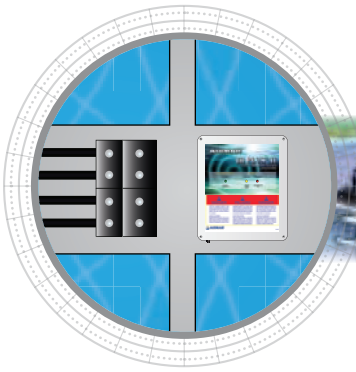

Technical Information

SPECIFICATIONS

Maximum Coverage: 3,000 square meters (32,291 square feet)

Battery Status and Transmitting Mode:

—Normal Mode—Operates when the battery voltage is above 22 VDC

—Power Save Mode—Automatically activated when the battery voltage drops below 22 VDC. It extends time between pulses without decreasing sound output. Power consumption is reduced by 50%

—Shut Down Mode—Activated whenever the battery voltage drops below 20 VDC

—Audible “Insufficient Power” Alarm—Sounds when the transmitter shuts down

Sound Projectors Withstand Harsh Marine Environments:

—Provided with weatherproof connectors allowing ease of installation and repositioning

—Cable can be lengthened or shortened with minimal loss of performance

—High visibility cable jacket with excellent abrasion resistance

Supply Voltage: 24 VDC

Output Power: 1.8 kW RMS pulse power output per transmitter

Audible “Insufficient Power” Alarm: 97 dB

Standard Cable Length: 60 m (200')

Power Consumption:

—1.7 Amps at 100% power

—0.9 Amps in power save mode is factory preset for 50% reduction

System Coverage*:

3,000 square meters (32,291 square feet) for typical aquaculture application

Patent Information:

—U.S. Patent Number 5,610,876

—Norwegian Patent Number 304001

—European Patent Number EP 0 706 317 131

Warranty:

—The dB Plus II system is backed by a full 12 month U.S. Manufacturer’s Limited Warranty covering defects in manufacture.**

—This system is designed to deter seals. Effectiveness with other species or with hearing impaired seals is neither insured nor implied.

Safety Notes:

To ensure safe operating practices, the transmitter cover label carries the following warnings for divers and operators:

—DANGER—Temporary or permanent hearing loss may result from underwater exposure to high-intensity sound generated by this equipment. This transmitters “On-Off” switch must be locked in the “Off” position whenever a person is underwater and within 150 m (492’) of a transducer

—NOTICE TO DIVERS—This transmitter’s “On-Off” switch must be locked in the “Off” position and the diver’s safety cover put in place over the transmitter box before entering the water. If the system is switched on accidentally, immediately surface at the normal ascent rate.

*This may vary for different species and sites.

**Breach of transmitter box seal voids warranty.

DIMENSIONS

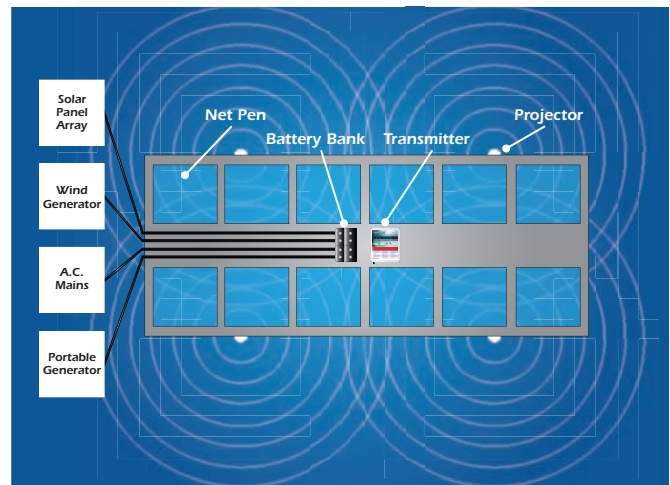
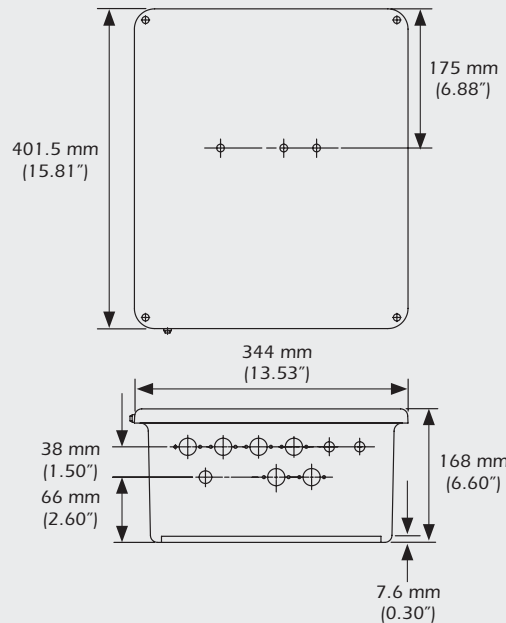

Options

- Power splitters allow the dB Plus II system to use up to eight sound projectors
- Customized transducer cable length up to 150 m (500')
- Cable splice kit