

R399



Frequency Agility

Airmar's new Broadband R399 is different from the R299 because it operates at lower frequencies between **25 kHz to 45 kHz** and **130 kHz to 210 kHz**. Adjusting the frequency allows you to change the R399's beamwidth and depth capabilities. For example if you are bottom fishing in 61 m (200') of water, the narrow high-frequency beam will display extreme bottom detail and fish holding tight to structure. If you are tuna or marlin fishing in deep blue water, the wider, low-frequency beam will not only give deep-water bottom detail, but more importantly show you more of what is around your vessel—including bait which may attract game fish.

Tunable Fishfinding

Because the R399 can operate over a broad high and low-frequency range, next generation fishfinders can be made "tunable", so fishermen can "dial-in" the best frequency for the target fish species or conditions.

In-Hull 2 - 3 kW HD Digital

Fishing Applications

- Offshore and long-range blue-water fishing
- Commercial fishing
- Deep-water canyon and sea-mount tracking

Features



- The best in-hull performer in Airmar's professional line of fishfinder transducers for vessels 12 m (40') and up
- Only 3 kW in-hull transducer on the market that can operate at 28 kHz, 38 kHz, or 45 kHz
- Depth only
- Super low ringing for accurate discrimination between closely spaced targets
- Recommended for solid fiberglass hulls
- Non-toxic anti-freeze (propylene glycol) is used to fill the tank
- Fiberglass resin is used to adhere tank to the hull

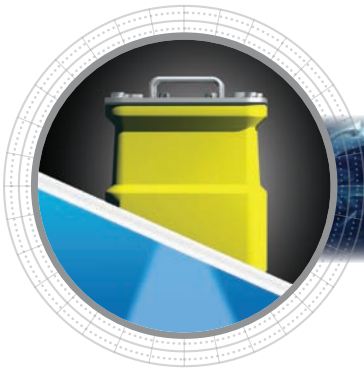

Sensing Technology



Technical Information

25-45 kHz-A / 130-210 kHz-BRIq		
Number of Elements and Configuration		
Beamwidth (@ -3 dB)	Adjustable	Adjustable
RMS Power (W)	3 kW	2 kW
TVR	169 dB @ 50 kHz	172 dB @ 200 kHz
RVR	-167 dB @ 50 kHz	-184 dB @ 200 kHz
FOM*	-5 dB @ 50 kHz	-12 dB @ 200 kHz
Q	3 @ 50 kHz	3 @ 200 kHz
Impedance	187 Ω @ 38 kHz	185 Ω @ 50 kHz
	169 Ω @ 140 kHz	208 Ω @ 200 kHz
	250 Ω @ 50 kHz	314 Ω @ 200 kHz

*Does not calculate losses through the hull.

MAXIMUM DEPTH RANGE	
Low-Frequency	High-Frequency
914 m to 1,372 m (3,000' to 4,500')	235 m to 353 m (800' to 1,200')

Directivity Pattern

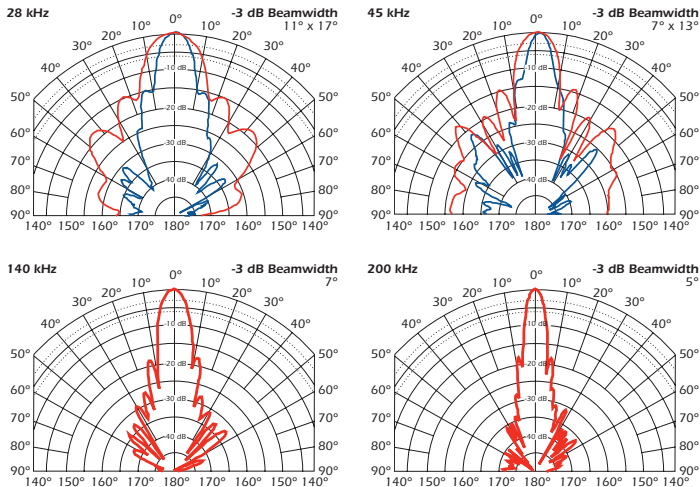

SPECIFICATIONS

Weight: 24.8 kg (54.8 lb)
Hull Deadrise: 0° to 22°
Acoustic Window: Epoxy/urethane
All mounting hardware provided, including tank

DIMENSIONS

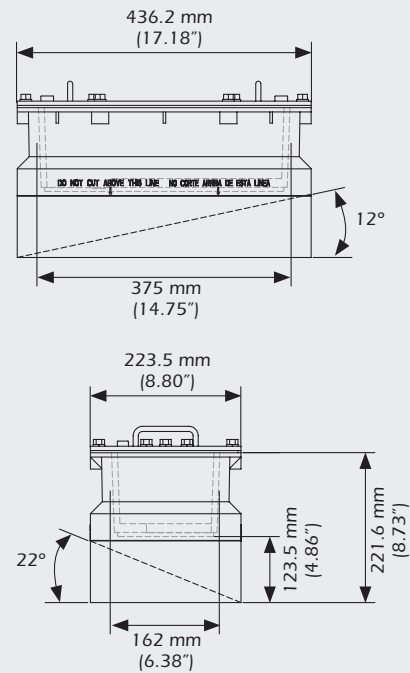

Figure of Merit

The graphs show that the R399 can run optimally at a wide range of frequencies.

